

## PT-SV110

### Scott Volumeter

The PT-SV110 Scott Volumeter determines bulk density of powders according to the following standard Monographs: ISO 3923-2 (metallic powders): determination of apparent density, EP <2.9.34.1> USP <616, Method II> bulk density and tapped density of powders and method II, ASTM 32990 standard test method for apparent density of metal powders and compounds.



The PT-SV110 is applicable to powders including metal powders, compounds, pigments, and so on that will flow freely through a suitable nozzle.

A comparison of the bulk and tapped densities of powders can give an indication of the type of interaction present between the various particles building up in the powder mass and hence provide an index of powder flowability, e.g., the Hausner ratio and compressibility index.

## Operating Principle

The operating principle relies on the measurement of a mass of a certain quantity of powder which fills a container of a known volume inside the PT-SV110. A loose packing condition is obtained by using the PT-SV110 and this is achieved by filling a stainless steel cup or container by cascading the powder sample over a series of inclined glass baffles within a baffle box. The ratio between the mass and the volume represents the apparent density.



The PT-SV110 is easy to use. First weigh then place the stainless steel cup onto the base of the unit. Then carefully pour the powder into the funnel at the top of the baffle box until the cup beneath overflows. Now level off the powder using a flat edge scraper.

Re-weigh the cup and calculate the weight of the collected powder sample. Now use the known volume of the cup to calculate the apparent density. This can be done using the formula:

$$\rho = M/V$$

Where  $\rho$  is the density, M = mass in grams and V = volume of the receiving cup in mL. The result is expressed in g/mL.

## The USP Procedure States

*“Allow an excess of powder to flow through the apparatus into the sample receiving cup until it overflows, using a minimum of 25cm<sup>3</sup> of powder with the square cup and 35cm<sup>3</sup> of powder with the cylindrical cup. Carefully scrape excess powder from the top of the cup by smoothly moving the edge of the blade of a spatula perpendicular to and in contact with the top surface of the cup, taking care to keep the spatula perpendicular to prevent packing or removal of powder from the cup. Remove any material from the sides of the cup, and determine the weight, M, of the powder to the nearest 0.1%.”*

## Setup of the PT-SV110 Instrument

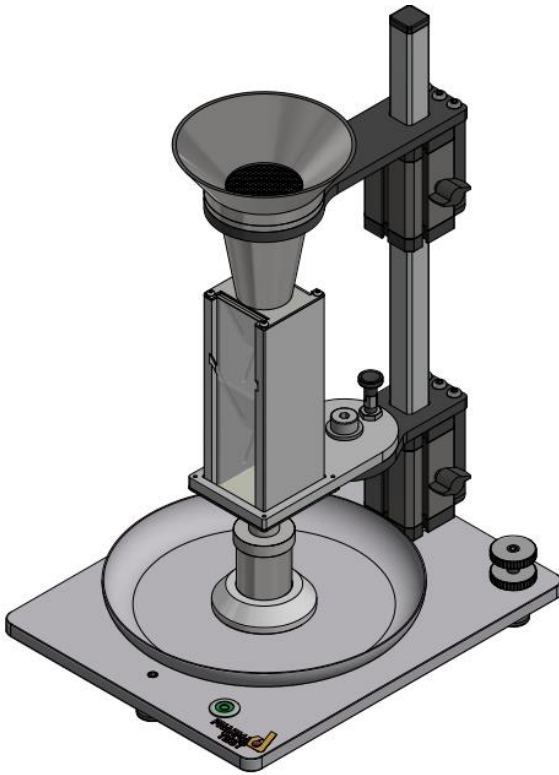

The instrument design consists of a solid baseplate, a stand to carry the funnel and baffle box, a stainless steel receiving cup. The height of the funnel and of the baffle box can be adjusted freely up and down and locked into place without a risk of twisting and without using any tools. After a test the baffle box can be swiveled to this side to allow easy access to the receiving cup.

The instrument includes a powder collecting tray, which can be easily removed for cleaning. The base plate with integrated spirit level can be adjusted via three points to ensure a level installation. A suitable balance is required to calculate the apparent density.

## Result Reporting

Usually there should be a series of at least three tests to provide a basic statistical set of results and to avoid any sample anomalies. Samples should be of a uniform nature and as such should be representatively sampled. This can be achieved by coning and quartering or by the use of suitable riffing device, either electronic or manual. When the test is finished you need to prepare a test report which should include product descriptive information such as batch number, specification, method of drying (if it has been dried).

### Advantages

- » An affordable and easy to use solution to determine density of powders
- » Simple to use and yet produces reliable results
- » Sturdy design using sliding profiles that can be locked into position
- » Includes levelling screws and spirit gauge

### Features

- » Fully ISO 3923-2 (metallic powders): determination of apparent density, EP <2.9.34.1> and USP <616, Method II> compliant
- » Applicable to powders including metal powders, compounds, pigments
- » Instrument comes ready to use, only an analytical balance is needed in addition

## Standard Scope of Supply

The PT-SV110 comes ready to use with the following standard scope of supply:

- » One stainless steel receiving cup
- » One powder scraper
- » One set of funnel meshes
- » Comprehensive documentation folder including:
  - > User manual
  - > DQ/QC instrument compliance test certificate
  - > IQ documentation
  - > OQ documentation
  - > Instrument logbook

## Technical Specifications

Parameter	Specification
<b>Receiving cup</b>	25 +/- 0.05ml, round, stainless steel
<b>Funnel mesh size</b>	1.0mm (18 mesh) and 2.00mm (10 mesh)
<b>Instrument dimensions</b>	Approx. Tbd mm (length x width x height)
<b>Packaging dimensions</b>	Approx. Tbd mm (length x width x height)
<b>Net / gross weight</b>	Approx. Tbd / Tbd kg
<b>Certification</b>	All components certified to ISO, USP and EP requirements
<b>CE certification</b>	All CE Certification provided
<b>Validation</b>	All IQ & OQ documents included

We reserve the right to make technical changes without any prior notice.